

# Capacitive power transfer to car through wheel - is it possible?

Sebastian Hall  
Industrial Electrical Engineering and Automation  
Lunds university  
Email: sebbe.hall@gmail.com

**Abstract**—This Paper evaluates the possibility to transfer electrical power from a metal plate to the steel-cord within a car tire. Impedance measurements show the capacitive impedance coupling between a plate and a steel-cord within a car tire that consists of a capacitive part that is fairly independent of the frequency (ca 200 pF), and a resistive part which is inversely dependent on the frequency (ca 4 k $\Omega$  at 10 kHz). Simulations and practical experiments show that the power transfer is limited due to the tire that is used in these experiments: the resistive part of the impedance coupling is too large. With a rubber compound with a lower dielectric loss angle though, sufficient power transfer might be achievable. More work regarding evaluating different rubber compounds - particularly when silica is used as filler instead of carbon black - should be done before this technique can be excluded as a possibility for electric roads.

## I. INTRODUCTION

With the ongoing discussion about global warming due to  $CO_2$  emissions and oil prices running high, an alternative to fossil-fuels in the transport-sector is becoming more and more relevant<sup>1</sup>. Electric cars seem to be a big factor in the transition from a fossil-fuel free vehicle fleet, but so far the limited driving range and the short lifetime of the battery have been limiting factors. These problems would be more or less reduced to zero with the possibility to charge the vehicle continuously while driving: the driving range would of course increase, and since the depth of discharge would decrease on the battery the lifetime would go up exponentially [2].

Inductive and conductive methods for delivering power from the road have been investigated thoroughly, but so far the possibility of capacitive power transfer has only been discussed briefly. [3] presents a suggestion that the tire of the car could be used as a capacitor, with the rubber working as a dielectric and the steel

<sup>1</sup>For example, Sweden aims to have a vehicle fleet completely independent of fossil-fuels till 2030 [1]



Fig. 1. Set-up for impedance measurements

cord within the tire as a conductor. Inspired by this idea, this work aims to further evaluate this technique by dividing up the problem in three major parts: Firstly, the impedance coupling between a steel plate and a car tire is measured. Secondly, an equivalent circuit model is presented to simulate the possible power transfer to a load resistance. Finally, experiments are conducted on a steel plate and a car tire, investigating how good the analytical model correlates with reality.

## II. IMPEDANCE MEASUREMENTS

Impedance measurements are made with a Hewlett Packard 4194A impedance analyzer on a Dunlop SP Sport Maxx Tire and a steel plate. The set-up for the measurements can be seen in Figure 1. The impedance is analyzed sweeping the frequency from 100 Hz to 100 kHz. Figure 2 shows the measured impedance divided up in a capacitive and a resistive part. As can be seen, the capacitance is fairly constant and has a value of around 200 pF, while the resistance is inversely dependent of the frequency and has a value of around 4 k $\Omega$  at 10 kHz frequency.

## III. ANALYTICAL MODEL

The proposed equivalent circuit for the power transfer of the forementioned system is shown in Figure ??.

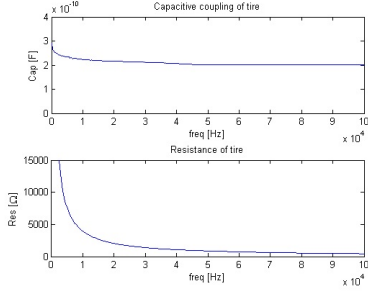

Fig. 2. Impedance coupling between steel plate and steel cord

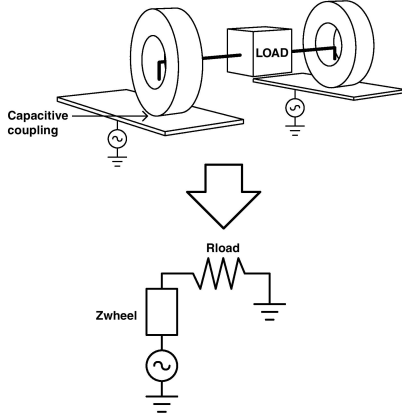

Fig. 3. Model of system

The load in the figure represent the power electronics, battery and electrical machine in the vehicle. Since the system is considered to be symmetrical, only one impedance coupling between the ground and the steel cord is taken into account for in the equivalent circuit. The analytical expression for the equivalent circuit of the system, considering a sinusoidal source voltage and a steady state situation, can be expressed using phasors as:

$$Z_{wheel} = R_{wheel} + \frac{1}{j\omega C_{wheel}} \quad (1)$$

$$I = \frac{U}{R_{load} + Z_{wheel}} \quad (2)$$

$$P_{load} = I^2 R_{load} \quad (3)$$

If a series inductance resonance filter is introduced to the system, the imaginary part of the wheel impedance is compensated for, and the current - hence the power - is limited only by the resistive part of the circuit. The analytical expression for the current become:

$$I = \frac{U}{R_{load} + R_{wheel} + (jL_{resonance} - j\frac{1}{\omega C_{wheel}})} \quad (4)$$

A square wave voltage is used in the practical experiments, and it is therefor necessary to analytically express the power transfer, not only for a sinusoidal source voltage, but for a square wave source voltage aswell. The average load power is calculated by integrating one period of the power wave and dividing it by the length of that period. If no resonance inductance is introduced, the system is of first order which implies that the power reaches steady state directly, and the power can be calculated using the first period of the power. The  $T$  in the expression (5) - which calculates the average power - is considered to be one voltage period, and since the power has twice as high frequency as the voltage, the integration is made from 0 to  $T/2$ . The  $I_0$  is the maximum amplitude of the current and  $\tau$  is the time constant.

$$\bar{p} = R_{load} I_0^2 \cdot \frac{2}{T} \int_0^{\frac{T}{2}} e^{-\frac{2t}{\tau}} dt \quad (5)$$

If a series inductance is introduced, the power will have a transient, and the integration has to be made on a period after the steady state situation is reached.

$$\bar{p} = R_{load} I_0^2 \cdot \frac{2}{T} \int_{\frac{T}{2}(n-1)}^{\frac{T}{2}n} \sum_{i=0}^n (-1)^i \theta(t - i\frac{T}{2}) (e^{-\frac{(t-i\frac{T}{2})}{\tau_1}} - e^{-\frac{(t-i\frac{T}{2})}{\tau_2}}) dt \quad (6)$$

#### IV. SIMULATION RESULTS

Figure 4 shows the power transfer as a function of the load resistance and the frequency of the source voltage, considering a resonance inductance to be present. The source voltage is considered to be sinusoidal and has a RMS value of 1600 V, which is the value that later on is used in the practical experiments<sup>2</sup>.

Figure 5 shows the power transfer, the loss power and the efficiency as a function of the load resistance when the voltage frequency is set to 10 kHz. As can be seen, the possible power transfer under these conditions is much to low to be able to drive a car, which would need a

<sup>2</sup>It is yet to be investigated which voltage amplitude that would be fit to use in a real life practical implementation. Since the power has a quadratic relation to the voltage, it is desirable to have an as high voltage amplitude as possible, but at the same time the system should be safe. More work considering which source voltage that should be used needs to be done.

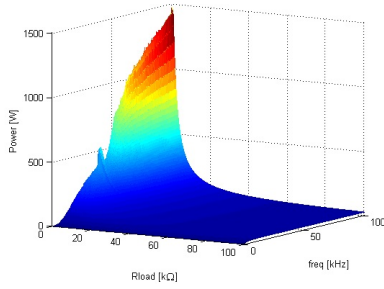

Fig. 4. Power transfer as a function of frequency and load resistance with resonance inductance

power transfer of at least 10 kW per capacitive coupling (four wheels on a car which means four capacitive couplings and 40 kW). Even with a high frequency and a low load resistance, the power transfer does not rise above 1.5 kW (Figure 4).

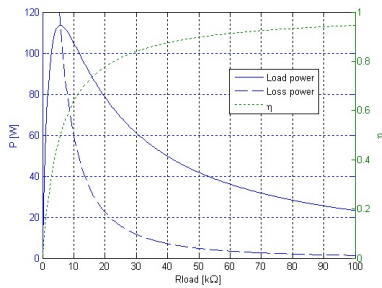

Fig. 5. Power transfer, loss power as a function of frequency and load resistance

## V. PRACTICAL RESULTS

The set-up for the practical experiments can be seen in Figure 6. A square wave voltage of 9750 Hz and an amplitude of 30 V is provided by a four-quadrant converter. A ferrite-core transformer with a ratio of 1:53.7 is used to achieve a source voltage of around 1600 V. The load consists of four resistors - two 10 kΩ and two 15 kΩ - connected in series creating a resistance of 50 kΩ.

Results for the load power, with a resonance inductance present, can be seen in Figure 7. The wave shape of the load power with a resonance inductance should theoretically be a sinus wave squared (the current becomes a sinusoid since the higher harmonics in the square wave are filtered away with the resonance inductance). The big peak in the wave shape is due to parasitic capacitance in the resonance inductance.



Fig. 6. Set-up for practical experiments

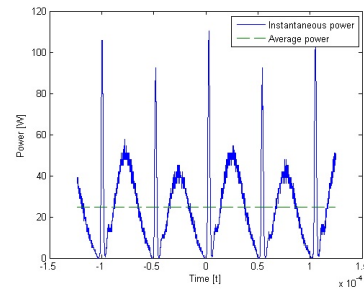

Fig. 7. Load power with resonance inductance

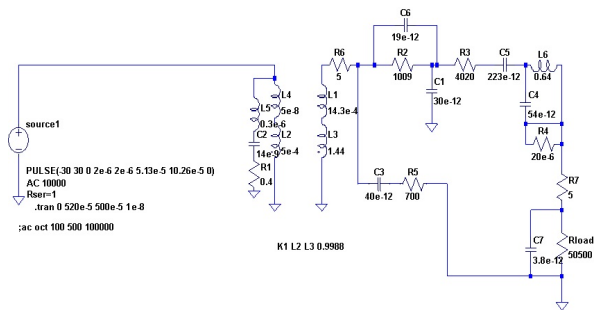

Fig. 8. LTspice model of system

Table I is comparing the numerical results from the practical experiments with results from the analytical model and from a LTspice model that is made to emulate the practical experiments as far as possible (Figure 8). As it can be seen, the power transfer is notably higher when the resonance inductance is implemented in the analytical model, compared to the results from practical experiments and the LTspice model. This is because of the imperfections in components used in the practical experiments (which are taken into account for in the LTspice model).

Comparisons			
	A. model	P. experiments	LTspice
Without resonance inductor,			
Power transfer	21 [W]	19.5 [W]	19.6 [W]
Efficiency	89 %	81 %	81 %
With resonance inductor,			
Power transfer	34 [W]	24.6 [W]	25.2 [W]
Efficiency	89 %	76 %	81 %

TABLE I

COMPARING NUMERICAL RESULTS FROM THE ANALYTIC MODELS, THE PRACTICAL MODELS AND LTSPICE SIMULATIONS

## VI. DISCUSSION

The results from this paper indicates limited power transfer capability for this technique in the electric road context. It should be mentioned though that the main limiting factor for the power transfer using this technique is the resistive part of the impedance coupling. If the resistive part is reduced, more power can be transferred at less losses and the concept can be truly interesting. The resistive part is mainly due to the dielectric loss angle in the tire rubber that works as a dielectricum for the capacitive coupling. The main reason for the high loss angle is the carbon black filler that is used to strengthen the tire [4]. With a different filler - for example silica [5] - the loss angle goes down, which maybe can make the possible power transfer sufficient. More work regarding this should be done.

Figure 9 shows a scenario where the loss angle of the tire rubber is decreased and how this would affect the power transfer. This simulation approximates the loss angle to be only dependent on the polarization losses, and that the dielectric constant ( $\epsilon'_r$ ) remains constant even though the loss factor ( $\epsilon''_r$ ) decreases. The expression for the tangens of the loss angle becomes [6]:

$$\tan(\delta) = \frac{\epsilon''_r}{\epsilon'_r} \quad (7)$$

Of course, Figure 9 shows a idealized case, but at least it gives a hint that with different dielectric properties of the rubber in the tire, a lot of electrical energy can pass through the tire with marginal losses.

## VII. CONCLUSION

This work concludes that the impedance coupling between the steel plate and the cord within the tire that is used in this experiment has a to big resistive part to be suitable for big capacitive power transfers. With a tire with different rubber compound dielectric properties

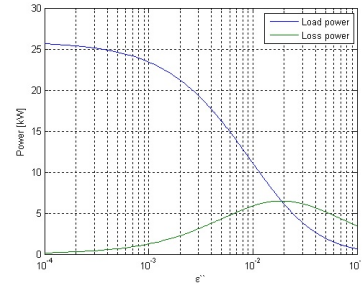

Fig. 9. Load power with resonance inductance

though, the technique might still be viable, and more research should be done before this concept is dismissed.

## REFERENCES

- [1] Energimyndigheten, *Energilget 2011*, 2011
- [2] Mats Alaküla, *Energy storage systems*, 2011, obtained from homepage: [http://www.iea.lth.se/hfs/Kurs%20ht11/Lectures/EHS\\_L4\\_2011\\_hybrid.pdf](http://www.iea.lth.se/hfs/Kurs%20ht11/Lectures/EHS_L4_2011_hybrid.pdf)
- [3] Masahiro Hanazawa, Takashi Ohira, *Power Transfer for a Running Automobile*, Microwave Workshop Series on Innovative Wireless Power Transmission: Technologies, Systems, and Applications (IMWS), 2011 IEEE MTT-S International
- [4] A. M. Bishai, A. M. Ghoneim, A. A. M. Ward & A. F. Younan, *Mechanical and dielectric properties of styrenebutadiene rubber polyester short-fiber composites: Part II. Composites loaded with high abrasion furnace carbon black*, 2010
- [5] A. A. Ward, A. I. Khalf, Dokki Cairo, *Inuence of TESPT on the PhysicoMechanical and Dielectric Properties of Silica Filled SBR Composites*, 2009
- [6] Walter S. Zaengl, Prof. em. Dr.-Ing. Swiss Federal Institute of Technology (ETH), Zurich, Switzerland, *Dielectric spectroscopy in time and frequency domain for hv power equipment (transformers, cables etc.)*, 2001 &